

CAMBO ULTIMA 35 OPEN UP YOUR SHOOTING POSSIBILITIES WITH ADDED FLEXIBILITY

Perfect for the Studio,
Architectural and Portrait Shooter



PHOTO BY TONY GLASER

THE ULTIMATE IN FLEXIBILITY

Shooting high-quality product shots in the studio requires *smooth precision movements* that allow you to control image shape, plane of focus and depth of field. ●

COMMERCIAL/PRODUCT

PORTRAIT/FASHION



PHOTO BY DAVID RADZINSKI

THE ULTIMATE IN DEPTH-OF-FIELD CONTROL

Creative portraiture, glamour and fashion photography are best explored with the swings and tilts of the view camera which enable you to play with *plane of focus* and other selective focusing techniques. ●

ULTIMA 35 CAMERA KITS

The Ultima 35 can be purchased in a variety of ways and packages. For those in the market for a complete digital camera solution, ask for a complete kit with the DSLR camera of your choice. For those that already own a DSLR camera, combine the appropriate kit with the second grouping. The Ultima 35 system of adapters and other DSLR-specific accessories will continue to be developed for future cameras that will be launched. Upgrading to a new DSLR will only require a new mounting block and vertical bracket, within the same bayonet system. All components are separately available.



THE ULTIMA 35 WITH NIKON D1X

Ultima 35 Base Camera without DSLR Camera
These kits include Ultima 35 and adapter kit for a specified digital camera.

- For Canon EOS 1D or 1Ds UL-KIT-C1ds
- For Kodak DCS Pro 14n UL-KIT-K14n
- For Nikon D1X UL-KIT-ND1x
- For Fujifilm FinePix S2 Pro UL-KIT-FS2

Ultima 35 System

The Cambo Ultima 35 accessory system expands the range of your shooting options to include other formats, lens systems and DSLR cameras and will continue to grow to accommodate new models as they develop.

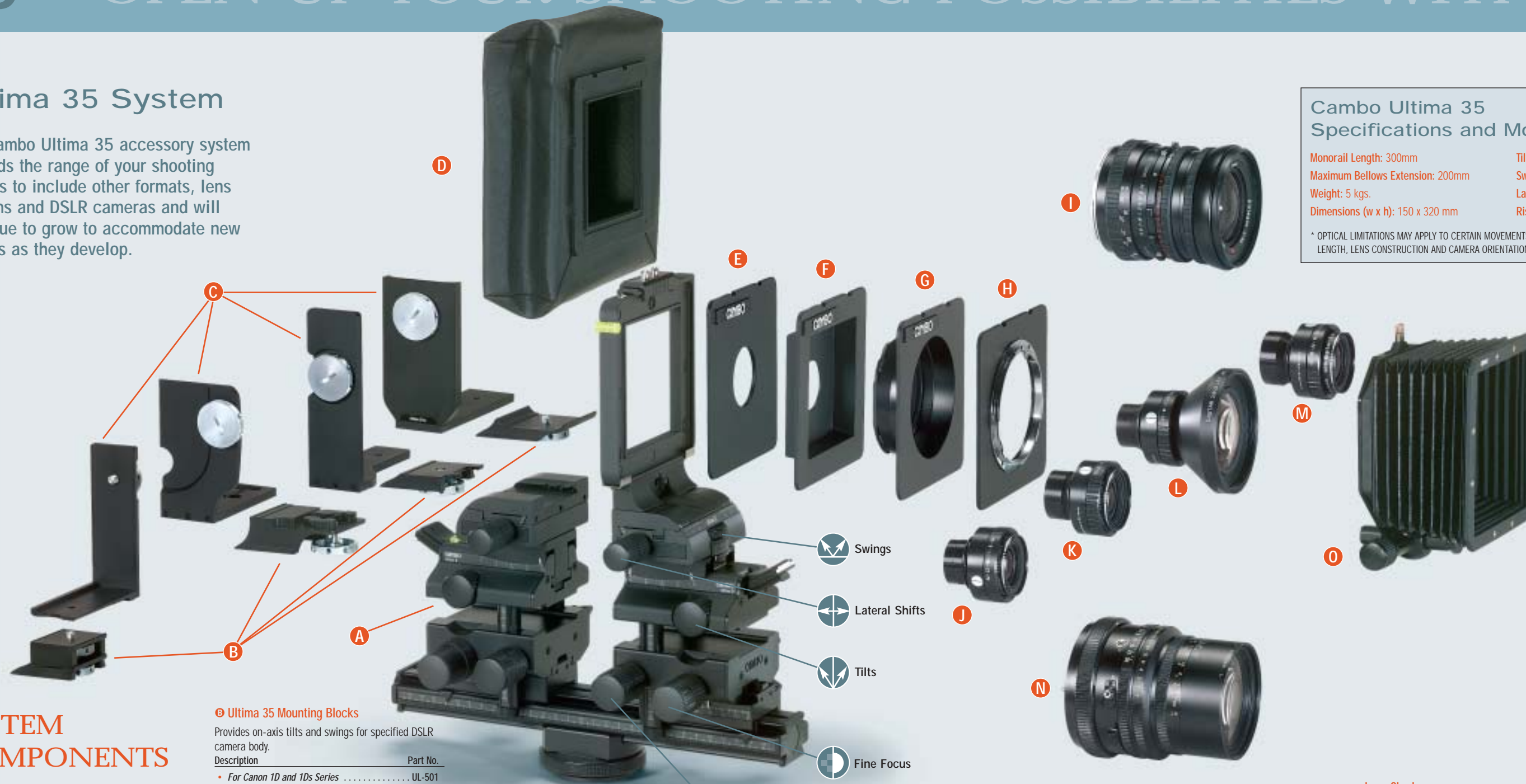

Cambo Ultima 35 Specifications and Movements*	
Monorail Length: 300mm	Tilts: ±20°
Maximum Bellows Extension: 200mm	Swings: ±30°
Weight: 5 kgs.	Lateral Shifts: ±20mm
Dimensions (w x h): 150 x 320 mm	Rise and Fall: ±20mm

* OPTICAL LIMITATIONS MAY APPLY TO CERTAIN MOVEMENTS DEPENDING UPON FOCAL LENGTH, LENS CONSTRUCTION AND CAMERA ORIENTATION (H/V).

SYSTEM COMPONENTS

Ultima 35 Mounting Blocks

Provides on-axis tilts and swings for specified DSLR camera body.

Description	Part No.
• For Canon 1D and 1Ds Series	UL-501
• For Canon 20 D	UL-550
• For Kodak DCS ProSLR /n	UL-502
• For Kodak DCS ProSLR /c	UL-503
• For Nikon D1X	UL-530
• For Nikon D2X	UL-532
• For Fujifilm FinePix S2/S3 Pro	UL-540

Ultima 35 Vertical Brackets

This accessory allows you to shoot in vertical format.

Description	Part No.
• For Canon 1D and 1Ds Series	UL-720
• For Canon 20 D	UL-750
• For Kodak DCS ProSLR /n	UL-721
• For Kodak DCS ProSLR /c	UL-722
• For Nikon D1X	UL-730
• For Nikon D2X	UL-732
• For Fujifilm FinePix S2 Pro	UL-740

Ultima 35 Adapter Kits

Includes bellows and camera mounting block.

Description	Part No.
• For EOS 1D and 1Ds Series	ULC-35
• For EOS 20D	ULC-20
• For Kodak DCS ProSLR /n	ULKn-35
• For Kodak DCS ProSLR /c	ULKc-35
• For Nikon D1X	ULN1X-35
• For Nikon D2X	ULN2X-35
• For Fujifilm FinePix S2 Pro	ULF-35

Ultima 35 Bellows

Includes fixed specified camera bayonet.

Description	Part No.
• For Canon EF Mount	ULBC-35
• For Nikon Mount	ULBN-35

Travel Case

Description	Part No.
• Case for Ultima 35	UL-200

LENS MOUNTS & LENSES

Lensboards and Adapters

Description	Part No.
• Flat Lensboard for Copal #0	SF-630
• Recessed Lensboard for Copal #0	SF-72
• Hasselblad Lens Adapter	ULH-23
• Mamiya RB Lens Adapter	ULMRB-23
• Mamiya 645 Pro Lens Adapter* (not shown)	ULM-645

Schneider Apo-Digital Lenses

These highly recommended lenses are designed to optimise the quality of your digital images. Digitars are shutterless and come with a NK aperture mount.

Description	Needs the lensboard
• 28mm f/2.8 W.A. Digital	SF-72
• 80mm f/4.0 Apo-Digital	SF-72
• 90mm f/4.5 Apo-Digital	SF-72
• 100mm f/5.6 Apo-Digital	SF-630
• 120mm f/5.6 Apo-Digital	SF-630
• 150mm f/5.6 Apo-Digital	SF-630
• 80mm f/5.6 Apo-Digital Macro	SF-72
• 120mm f/5.6 Apo-Digital Macro	SF-630
• 180mm f/5.6 Apo-Digital Macro	SF-631

Lens Shade

Description	Part No.
• Cambo Compendium Lens Shade	UL-343

Medium Format Lens Options

The Ultima 35 can be adapted to accept several medium format lens systems.

- Hasselblad CF Lenses
- Mamiya RB Lenses
- Mamiya 645 Pro Lenses*

* Only for use with Canon bodies.

For more details on the ever-growing Ultima 35 system, visit www.cambo.com.

ULTIMA 35 CONVERSION KITS

To further enhance the digital flexibility of the Ultima 35, these kits adapt the camera to accept a variety of medium format digital backs and 4x5 high-resolution scanning backs and even film.



Ultima 35-to-Ultima 23 Conversion Kit

This kit allows you to shoot with medium format digital backs, including Leaf, Kodak, Phase One and Imacon. Kit includes a 2 1/4 x 3 3/4" rear frame and a bag bellows. Requires a direct adapter for backs with live video focusing or a Multistep Sliding Back (listed below). UL-471



ULTIMA 35-TO-ULTIMA 23 CONVERSION KIT SHOWN WITH OPTIONAL MULTISTEP SLIDING BACK AND PHASE ONE H20 DIGITAL BACK.

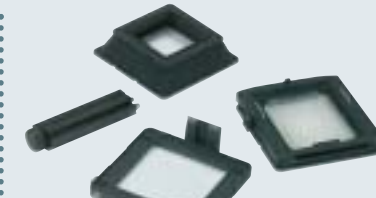

Ultima 35/23-to-Ultima 4x5 Conversion Kit

Convert your Ultima 35 or Ultima 23 to a 4x5 film camera with this kit which includes a 4x5 rear frame, a 4x5 international ground glass back, a tapered bellows and a monorail extension. UL-470



ULTIMA 35/23-TO-ULTIMA 4X5 CONVERSION KIT SHOWN MOUNTED.

Ultima 4x5-to-Ultima 35 Adapter (not shown)

Converts your Ultima 4x5 into an Ultima 35. The kit includes an Ultima 35/23 front standard and requires a DSLR adapter kit. UL-472

Cambo Multistep Sliding Back

This back mounts directly to the 2 1/4 x 3 3/4" rear frame and accepts most medium format digital backs from Imacon, Kodak, Leaf and Phase One. The Multistep Sliding Back can be used to capture individual images or can be used to place two or three images next to each other where they can be "stitched" with special software into larger file images such as spreads or panoramas. Multistep Sliding Back requires mounting plate for specific model backs. As new digital formats are introduced, Cambo will develop new products to accommodate them. Medium format backs require lenses with shutters and possibly special dedicated cable releases.

Description	Part No.
• Multistep Sliding Back for 6/11 mp	CMSL-369
• Multistep Sliding Back for 16/17/22 mp	CMSL-269

Be sure to visit www.cambo.com for complete accessory listings for the Ultima 35 system and adaption information on medium format digital backs.



PHOTO BY CHARLIE MAYER

COMMERCIAL/PRODUCT

ARCHITECTURE

THE ULTIMATE IN PERSPECTIVE-CONTROL MOVEMENTS

Accurate architectural renderings require substantial *perspective control movements* and subject-placement shifts that are only fully realised with the use of a view camera. ●